



WIPO Guide to Using **PATENT** **INFORMATION**



WORLD
INTELLECTUAL
PROPERTY
ORGANIZATION

<http://www.wipo.int/patentscope>

Table of Contents

Introduction	3
How does the patent system work?	3
Protection	3
Disclosure	6
Why use patent information?	6
What information does a patent document contain?	7
Where can patent information be found?	10
Which strategies can be used to search patent information?	11
Search by keyword	12
Search by patent classification	15
Search by number/date ranges	18
Search by applicant/assignee name or by inventor name	20
Search in specific data fields	21
Using citations and reference information	22
Good practices in searching patent documentation	24
How can patent information be used?	26
Prior art searches	26
Gathering business intelligence	32
Avoiding patent infringement	36
Patent valuation	37
Identifying key trends in technology development	38
Where can non-patent literature be located?	42

►► Introduction

Access to technology information has expanded rapidly in recent years, a result of the increasing availability of technical documents in digital format and the progressive development of electronic means of distribution and retrieval. As the quantities of technology information available to the public have grown, so too have the challenges of finding relevant information from which useful knowledge can be extracted.

This Guide aims to assist users in searching for technology information using patent documents, a rich source of technical, legal and business information presented in a generally standardized format and often not reproduced anywhere else. Though the Guide focuses on patent information, many of the search techniques described here can also be applied in searching other non-patent sources of technology information.

►► How does the patent system work?

A patent has two important functions:

- **Protection.** A patent allows the patent holder to exclude others from commercially exploiting the invention covered by the patent in a certain country or region and for a specific period of time, generally not exceeding 20 years.
- **Disclosure.** A patent gives the public access to information regarding new technologies in order to stimulate innovation and contribute to economic growth.

Protection

A patent application may be filed via one of the following routes:

- **National.** An application for a patent is generally filed at a national patent office and a patent for an invention may be granted and enforced only in that country in which patent protection is requested, in accordance with the law of that country. The same application can be filed in accordance with the respective national patent laws in different countries on an individual country-by-country basis.

- **Regional.** In some regions, regional patent applications may be filed at a regional patent office, for example the African Regional Intellectual Property Organization (ARIPO) or the European Patent Office (EPO). Regional patent applications have the same effect as applications filed in the member states of the regional patent agreement and are in certain cases granted centrally as a “bundle” of patents by the regional patent office. Validation nationally may also require submission of a translation of the granted patent into the national language.
- **International.** International applications may be filed with the patent offices of Contracting States of the Patent Cooperation Treaty (PCT) or the International Bureau of the World Intellectual Property Organization (WIPO) by any resident or national of a PCT Contracting State. A single international patent application has the same effect as national applications filed in each designated Contracting State of the PCT. Although the major part of the patent application procedure is carried out within the international phase, a patent can only be granted by each designated State within the subsequent national phase.

Although procedures vary amongst patent offices, the following illustrates a very generalized procedure for granting a patent:

- **Filing.** An applicant chooses a filing route, i.e. national, regional or international, and files an application. The initial filing is considered the “priority filing” from which further successive national, regional or international filings can be made within the “priority period” of one year under the Paris Convention for the Protection of Industrial Property.
- **Formal examination.** The patent office ensures that all administrative formalities have been complied with, e.g., that all relevant documentation is included in the application, and that all filing fees have been paid.
- **Prior art search.** In many countries, but not all, the patent office carries out a search of the prior art, i.e., of all relevant technological information publicly known at the time of filing of the patent application. Using extensive databases and expert examiners in the specific technical field of the application, a “search report” is drafted, which compares the technical merits of the claimed invention with that of the known prior art.

- **Publication.** In most countries, the patent application is published 18 months after the priority date, i.e., after the first filing date.
- **Substantive examination.** If a prior art search report is available, the examiner checks that the application satisfies the requirements of patentability, i.e., that the invention is novel, inventive and susceptible to industrial application, compared to the prior art as listed in the search report. The examiner may either grant the patent application without amendments, may change the scope of the claims to reflect the known prior art, or may refuse the application.
- **Opposition.** Within a specified period, many patent offices allow third parties to oppose the granted patent on the grounds that it does not in fact satisfy patentability requirements.
- **Appeal.** Many offices provide the possibility of appeal after the substantive examination or after the opposition procedure.

Patent granting procedure

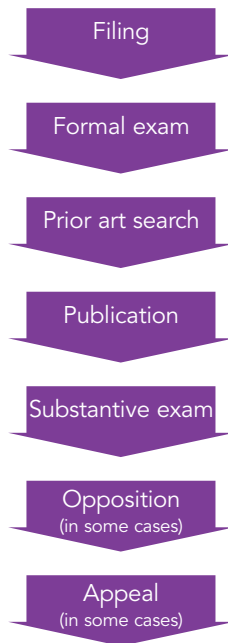

Disclosure

The second important function of the patent system is disclosure, i.e., a patent gives the public access to information regarding new technologies in order to stimulate innovation and contribute to economic growth.

Though the protection offered by a patent is territorial, covering only the jurisdiction in which the patent has been granted, the information contained in a patent document is global, available as a disclosure to any individual or organization worldwide, thus allowing anyone to learn from and build on this knowledge.

▶▶ **Why use patent information?**

Patent information is an important resource for researchers and inventors, entrepreneurs and commercial enterprises, and patent professionals. Patent information can assist users to:

- Avoid duplicating research and development effort;
- Determine the patentability of their inventions;
- Avoid infringing other inventors' patents;
- Estimate the value of their or other inventors' patents;
- Exploit technology from patent applications that have never been granted, are not valid in certain countries, or from patents that are no longer in force;
- Gain intelligence on the innovative activities and future direction of business competitors;
- Improve planning for business decisions such as licensing, technology partnerships, and mergers and acquisitions;
- Identify key trends in specific technical fields of public interest such as those relating to health or to the environment and provide a foundation for policy planning.

▶▶ What information does a patent document contain?

Patent information comprises all information which has either been published in a patent document or can be derived from analyzing patent filing statistics and includes:

- **Technical information** from the description and drawings of the invention;
- **Legal information** from the patent claims defining the scope of the patent and from its legal status;
- **Business-relevant information** from reference data identifying the inventor, date of filing, country of origin, etc.;
- **Public policy-relevant information** from an analysis of filing trends to be used by policymakers, e.g., in national industrial policy strategy.

In particular, this information refers to the following:

- **Applicant.** Name of the individual or company applying to have a particular invention protected;
- **Inventor.** Name of the person or persons who invented the new technology and developed the invention;
- **Description.** Clear and concise explanation of known existing technologies related to the new invention and explanation of how this invention could be applied to solve problems not addressed by the existing technologies; specific embodiments of the new technology are also usually given;
- **Claims.** Legal definition of the subject matter which the applicant regards as his invention and for which protection is sought or granted; each claim is a single sentence in a legalistic form that defines an invention and its unique technical features; claims must be clear and concise and fully supported by the description;
- **Priority filing.** Original first filing on the basis of which further successive national, regional or international filings can be made within the priority period of one year;¹

¹ A group of applications based on a single application as described above is referred to as a "patent family." Identifying the members of a patent family will not only reveal in which countries or regions patent protection is being sought by an applicant, but may also uncover translations of the application in different languages.

- **Priority date.** Date of the first filing from which the innovation is protected if the application is successful and from which the one-year priority period for further applications starts;
- **Filing date.** Date of submitting an individual patent application at a particular patent office and, therefore, the date from which the innovation is protected if the application is successful;
- **Designated states.** If the application is regional or international, the countries to which the rights may be extended;
- **Legal status.** Indicates whether the patent has been granted or not; if granted, the countries or regions in which the patent has been granted; and whether it is still valid or has expired or been invalidated in a particular country or region;
- **Citation and references.** Certain patent documents also include references to related technology information uncovered by the applicant or by a patent examiner during the patent granting procedure; these references and citations include both patent and non-patent documents;
- **Bibliographic data.** Refers generally to the various data appearing on the front page of a patent document or the corresponding applications and may comprise document identification data, domestic filing data, priority data, publication data, classification data, and other concise data relating to the technical content of the document;
- **Document kind codes.** Used to distinguish published patent documents according to type and status (see WIPO Standard ST.16); for example, the code A1 denotes a published application complete with an International Search Report (ISR), while the code A2 indicates a published application without an ISR, and the code A3 designates an ISR published separately from an application;
- **INID codes** (“Internationally agreed Numbers for the Identification of [bibliographic] Data”). Identify different elements of bibliographic data (see WIPO Standard ST.9); for example, the code 11 is associated with the patent number and the code 54 is associated with the title of the invention; the full list of INID codes can be found at:

<http://www.wipo.int/standards/en/pdf/03-09-01.pdf#INID>

- Country codes.** Specify different countries by a unique two-letter country code (see WIPO Standard ST.3); for example, the code "WO" indicates the International Bureau of WIPO; a list of country codes is given at:

<http://www.wipo.int/standards/en/pdf/03-03-01.pdf#codes>

Sample patent application front page

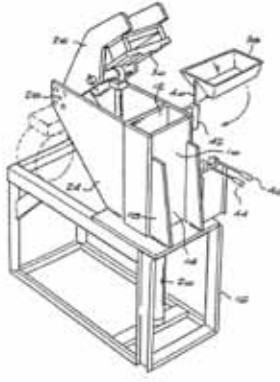
(12) INTERNATIONAL APPLICATION PUBLISHED UNDER THE PATENT COOPERATION TREATY (PCT)	
(19) World Intellectual Property Organization International Bureau	
	
(43) International Publication Date 16 August 2001 (16.08.2001)	
PCT	
(11) International Publication Number WO 01/58654 A1	
Classification	(71) International Patent Classification: B28D 2/08
Filing date	(72) International Filing Number: PCT/001/00155
Priority data	(21) International Filing Date: 9 February 2001 (09.02.2001)
Applicant	(22) Filing Language: English
Inventor	(23) Publication Language: English
Title	(24) Priority Data: 2000/0609 9 February 2000 (09.02.2000) ZA
	(73) Applicant (for all designated States except US): HYDRAFORM INTERNATIONAL LIMITED (I/WH/LE) DeLuxe & Trade House, Plot 20044, Fairground Office Park, Gaborone (BW)
	(74) Inventor, and (75) Inventor/Applicant (for US only): KOFARU, Jackson (ZA/ZA) 23 Sains Street, 1479 Somerset Park (ZA)
	(76) Agents: GILSON, David, Grant et al., Spoor and Fisher , P.O. Box 41312, 2024 Craighall (ZA)
	(81) Designated States (nationally): AE, AG, AL, AM, AT, AU, AZ, BA, BB, BG, BR, BY, BZ, CA, CH, CN, CR, CU, CZ, DE, DK, DM, DZ, EC, EG, ES, FI, GB, GR, GT, HK, HM, HU, ID, IL, IN, IS, JP, KE, KG, KP, KR, KZ, LC, LK, LR, LS, LT, LU, LV, MA, MD, MG, MK, MN, MW, MX, MY, NZ, PE, PG, PH, PT, RU, SD, SE, SG, SI, SK, SL, TJ, TM, TR, TT, TZ, UA, US, UZ, VN, YU, ZA, ZW
	(84) Designated States (regionally): ARIPO patent (DH, GM, KE, LS, MF, MG, SI, SL, SZ, TZ, UG, ZW), Eurasian patent (AM, AZ, BY, KG, KZ, MD, ES, FI, FR, GB, GR, IT, PL, PT, RU, SI, SK, TR), OAPI patent (BF, BJ, CF, CG, CI, CM, GA, GN, GW, ML, MR, NE, NG, SN, TD, TG)
	<i>(Continued on next page)</i>
	(54) Title: BLOCK FORMING APPARATUS
	(57) Abstract: Block forming apparatus comprises a compression chamber with upper and lower rams. A main ram extends into the compression chamber from the lower end, while an auxiliary ram is mounted on a pivoting arm and can be moved into the upper end of the compression chamber. A self-locking means is mounted into the compression chamber and a pre-compression stroke is carried out by the upper ram (20), before a main compression stroke is carried out by the lower ram (10). The opening force applied by the upper ram is substantially less than that applied by the lower ram.
	

►► Where can patent information be found?

Patent information is made available to the public through a variety of databases. Each database covers a particular set of patent documents. At present no database has complete coverage of all patent documents ever published worldwide. Thus it may be necessary to consult multiple databases in order to find and then access patent documents relevant to your interests.

Many national and regional patent offices provide free online access to their own patent collections as well as to selected patent documents from other offices. An extensive list of national patent databases can be found at:

http://www.wipo.int/patentscope/en/search/national_databases.html

WIPO offers free online access to all international patent applications within the framework of the PCT² and their related documents through its PATENTSCOPE® search service:

<http://www.wipo.int/patentscope>

A number of commercial and non-profit providers also offer free patent information databases online. Certain commercial providers have established value-added services for access on a fee-paying basis including translations of patent information and additional systematic classification, for instance by chemical structures and reactions or biological sequences.

Moreover, professional search services exist that can perform prior art searches on behalf of potential patent applicants and may be useful if an initial search does not produce desired results.

An extensive list of patent service providers can be found at:

<http://www.piug.org/vendors.php>

² For more information on the Patent Cooperation Treaty, please refer to <http://www.wipo.int/pct/en/treaty/about.htm>

▶▶ Which strategies can be used to search for patent information?

A search carried out in patent documents allows you to find information on recent developments in a range of technical areas. In fact, for some fields of technology, new developments are initially and sometimes exclusively recorded in patent documents. Nonetheless, it is critical to keep in mind the limitations of the data in which the search is being carried out. No single data source covers all available technology information, or even all available patent information. The information may be limited with respect to the range of dates or countries for which records are available or in terms of the search facilities offered.

Effective searching of patent documentation and other sources of technology information often requires a solid knowledge of the technical field to which an invention belongs. An awareness of the terminology and issues related to this field are necessary if appropriate search criteria are to be identified.

Among the search criteria that can be used to find relevant patents are:

- Keywords
- Patent classification
- Dates (e.g., priority date, application date, publication date, grant date)
- Patent reference or identification numbers (application number, publication number, patent number)
- Names of applicants/assignees or inventors

The criteria supported by different search services may vary. Some search services allow patent documents to be searched according to a broader range, others by a more limited range of criteria.

The sections of patent documents that can be searched using the above criteria may also differ from one search service to another. Most search services permit users to search bibliographic/front page data, that is all data contained in a patent application except the description and claims. Some search services, including the WIPO PATENTSCOPE® search service, allow full-text searches, including the description and claims. The range of searchable data may also be more limited for older patent documents. In some cases, for instance, these documents can only be searched, for instance, according to their title or patent reference number.

Careful!

Time lag between filing and publication. The period between the date of filing and the date of publication is 18 months. Nonetheless, if a patent is granted, its owner is allowed to exclude third parties from commercially exploiting the technology covered from the date of filing. In order to reduce the potential of infringing someone else's rights, patent documentation in the relevant country or region should be monitored to reveal the very latest published patent documents.



Some search services allow you to take advantage of notification systems such as RSS feeds to track developments in a specific field of technology.

Search by keyword

Patent information databases can generally be searched using keywords that describe the technology or problem the technology is designed to solve.

To target searches effectively, the following tools can be used:

- **Word operators** (Boolean operators). Keywords can be combined and/or excluded using so-called "Boolean operators" such as: "AND", "ANDNOT" (or simply "NOT"), "OR", "XOR", and "NEAR", for example:

tennis AND ball	→	documents having both the word "tennis" and "ball"
tennis ANDNOT ball	→	documents having the word "tennis" but not "ball"
tennis OR ball	→	documents having either the word "tennis" or "ball" or both
tennis XOR ball	→	documents having either the word "tennis" or "ball" but not both
tennis NEAR ball	→	documents having both the words "tennis" and "ball" within a certain number of words of each other ³

The "NEAR" operator may be useful to include variations on phrases containing two terms (e.g., "metal cutting", "cutting metal", "cutting of metal", and "cutting through metal") but to exclude documents in which the terms appear out of context with each other, which might occur if the "AND" operator is used.

- **Truncation.** Words can be truncated, i.e., shortened to their primary root or stem, by reducing its length using an operator called a wildcard, usually an asterisk (*), question mark (?), dollar sign (\$), or percent sign (%), so as to increase the coverage of the search, for instance:

elect*	→	all documents having words based on the word stem "elect," e.g., "electricity", "electrical", "electron" (but will also include words such as "election", "electoral", etc., which might not be relevant to a specific search, e.g., for electricity-related technology)
--------	---	--

Some search services allow both left and right truncation but many such as the WIPO PATENTSCOPE® search service only allow right truncation. Certain search services treat all search terms as word stems without requiring the use of wildcards.

³ In WIPO's PATENTSCOPE® search service, the default range within which search terms joined with the NEAR operator must lie is 5 words. A user-defined range may be specified by adding a colon (:) and desired number behind the NEAR operator (e.g., "tennis NEAR:10 ball").

- **Nesting.** Nesting refers to the use of parentheses to organize search queries in order to resolve potentially confusing search syntax, for example:

tennis AND ball OR racket	→	two potential search outcomes to be resolved
(tennis AND ball) OR racket	→	documents having either the words "tennis" and "ball" or the word "racket"
tennis AND (ball OR racket)	→	documents having the word "tennis" and either the word "ball" or "racket"

The default order in which different operators are applied in the absence of parentheses may vary between search services. Consequently, nesting must be used when mixing Boolean operators in order to ensure that a search is carried out as expected.

- **Phrases.** If you surround a group of words with quotation marks ("), everything surrounded by those quotation marks will be treated as a single search term. This allows you to search for a multi-word phrase rather than specifying each word as a separate term, for instance:

tennis ball	→	documents having both the words "tennis" and "ball" (by default often treated as an "AND" clause)
"tennis ball"	→	documents having the phrase "tennis ball"

Careful!

Multiple languages. Patent documentation is available in a number of languages. This fact must be taken into account when conducting patent searches. For example, international patent applications filed under the Patent Cooperation Treaty (PCT) must have the title and abstract available in both English and French, but other parts of the application (e.g., description and claims) can be in a number of other languages. Therefore, a search using English language terms may only retrieve results with English language text. Certain terms can exist in multiple languages but have different meanings in each language. For example, the term “vent” describes an opening or outlet in English but means “wind” in French.

Misspelling. In spite of quality control mechanisms built into the patenting process, terms may not always be spelled correctly.

Synonyms or scientific names. Technologies can often be described using a variety of different technical or common terms.



Brainstorm for synonyms (e.g., using specialized technical dictionaries) and try to find a general concept central to the invention (essential technical feature or core technical subject matter). Keywords identified in this manner can be combined using the search tools described above (Boolean operators, truncation, and nesting).

Search by patent classification

All patent documents are individually classified using a standardized system identifying the technology group or groups to which the innovation described in the document belongs. These classification systems are independent of language and terminology and are assigned to patent and other technical documents by professional patent examiners. As a result, searching patent documents by patent classification can help overcome some of the pitfalls of searching by keywords alone.

A widely used system is the International Patent Classification (IPC) system. More information about the IPC system is available at: <http://www.wipo.int/classifications/ipc>

The IPC system covers nearly every imaginable field of technology. The IPC is regularly revised in order to improve the system and to take account of technical developments. In its

eighth edition, it subdivides technology into almost 70 000 fields or groups. Each group describes a specific technology and is identified by a “classification symbol” consisting of a sequence of numbers and letters. IPC symbols can generally be found in the bibliographic data contained in published patent documents.

The IPC system is organized according to hierarchical levels. From highest to lowest; these levels are: sections, classes, subclasses, and groups (main groups and subgroups). Each section has a title and specific letter code, as follows:

A	Human Necessities
B	Performing Operations; Transporting
C	Chemistry; Metallurgy
D	Textiles; Paper
E	Fixed Constructions
F	Mechanical Engineering; Lighting; Heating; Weapons; Blasting
G	Physics
H	Electricity

From section (highest hierarchical level) to sub-group (lowest hierarchical level), the code “C21B 7/10” can, for instance, be broken down as follows:

- ➔ Section C: Chemistry; Metallurgy
- ➔ Class C21: Metallurgy of iron
- ➔ Subclass C21B: Manufacture of iron or steel
- ➔ Main group C21B 7/00: Blast furnaces
- ➔ Subgroup C21B 7/10: Cooling; Devices therefor

A search performed using, for example, the subclass C21B will return all records classified under the main group C21B 7/00 as well as the main groups C21B 3/00, C21B 5/00, and so forth.

Subgroups are further subdivided with one or more dots preceding their title indicating the hierarchical position of each subgroup. A subgroup with a certain number of dots forms a subdivision of the nearest subgroup above it having one dot less. In the example on the next page, subgroups C02F 1/461 and C02F 1/469 (two-dot level) represent subdivisions of the subgroup C02F 1/46 (one-dot level).

IPC classification dot-levels

<i>C02F 140</i>	- Devices for separating or removing fatty or oily substances or similar floating material (cleaning or keeping clear the surface of open water from oil or like materials: E02B 15/04; devices in sewers for separating liquid or solid substances from sewage E03F 5/14, e.g. for use in drains leading to the sewer E03F 5/16) [3,5]
<i>C02F 142</i>	- by ion-exchange (ion-exchange in general B01J) [3]
<i>C02F 144</i>	- by dialysis, osmosis or reverse osmosis [3]
<i>C02F 146</i>	- by electrochemical methods [3,5]
<i>C02F 1461</i>	- - by electrolysis [5]
<i>C02F 1463</i>	- - - by electrocoagulation [5]
<i>C02F 1465</i>	- - - by electroflotation [5]
<i>C02F 1467</i>	- - - by electrochemical disinfection [5]
<i>C02F 1469</i>	- - by electrochemical separation, e.g. by electro-osmosis, electrodialysis, electrophoresis [5]
<i>C02F 148</i>	- with magnetic or electric fields (C02F 146 takes precedence) [3]

A new feature introduced in the current eighth edition of the IPC is a two-tiered system of classification, designed to better meet the differing needs of small, medium-sized and large industrial property offices and the general public. The system consists of a core level and an advanced level, where the advanced level is an extension of the core level including approximately 50 000 additional sub-groups. In searching for patent documents using IPC symbols, it is critical to determine according to which level patent documents have been classified in the database being used.

Advanced level symbols are generally printed or displayed in italics, while core level symbols are given in regular (non-italics) font. Classification codes printed or displayed in bold indicate invention information, while regular (non-bold) font indicates additional non-invention information. For example:

<i>B28B 1/00</i>	→	advanced level, invention information
B28B 1/00	→	core level, invention information
<i>B28B 1/00</i>	→	advanced level, additional information
B28B 1/00	→	core level, additional information

Note that the IPC symbol given in the example above is both a core level and advanced level symbol.

In order to identify relevant IPC symbols, a keyword search of the IPC can be performed on the WIPO website at:

<http://www.wipo.int/tacsy>. Entering keywords into the system will return a list of possible IPC symbols related to the terms entered.

Other notable classification systems used by patent offices include the:

- European Classification (ECLA) system, which is based on the IPC but which is further subdivided into specific subgroups;
- File Index (FI) system, used by the Japan Patent Office, based on the IPC but with additional subdivisions and additional classification elements (“F-terms”) used to indicate particular technical features or aspects of an invention;
- US Patent Classification system, used by the US Patent and Trademark Office, which is a separate classification system (not based on the IPC).

Careful!

Lag in IPC reclassification. The IPC is revised periodically to take into account new technological developments. The eighth edition of the IPC entered into force on 1 January 2006. Patent applications published after the entry into force of a new edition of the IPC generally bear the codes of the newest edition, but some older patent documents may not be immediately reclassified (or may not be reclassified at all) and can thus only be located using IPC symbols from earlier editions of the IPC or other (non-IPC) search methods.

Search by number/date ranges

Patent documents are assigned unique identification numbers at each stage in the patenting process, i.e.:

- an application number;
- a publication number; and
- a patent number, if the patent is granted by a competent national or regional authority.

Also recorded in patent documents are key dates, including the:

- date of filing;
- date of publication; and
- priority date (the date of filing of the patent application on the basis of which priority is claimed).

When granted, national or regional patent applications receive a date of granting. International patent applications entering the national phase are given a national application number and national phase entry date and are later assigned information regarding possible grant, refusal or withdrawal.

Patent documents can be located using the identification numbers and key dates assigned to them. Some search services support the use of range operators to narrow the search in numerical fields, including date fields. Common range operators can include: greater than (>), less than (<), greater than or equal to (>=), less than or equal to (<=) and unequal to (<>). The WIPO PATENTSCOPE® search service uses the -> operator to specify a range of dates, for instance:

DP/20070908 -> 20071231 → documents with a publication date (DP) between 8 September 2007 and 31 December 2007

The WIPO PATENTSCOPE® search service supports a variety of date formats including:

YYYYMMDD,	e.g.: 19981201
DD.MM.YY or DD.MM.YYYY,	e.g.: 1.12.97 or 1.12.1997
DD/MM/YY or DD/MM/YYYY,	e.g.: 1/12/97 or 1/12/1997
DD-MM-YY or DD-MM-YYYY,	e.g.: 1-12-97 or 1-12-1997

Careful!

Variation in number and date formats. Number and date formats may vary across databases. Patent identification numbers can differ in length and may include country codes, region codes, letter codes indicating type of protection, zeros, spaces, special characters (slashes, commas, periods, etc.), and document kind codes. Each patent office determines the number format to be used for the patent documents it issues, which may in fact change over time as offices change their numbering practices or as a result of legislative changes. Though some databases maintain patent reference numbers in the same format as they are given by the issuing patent office, many databases, particularly those that include patent documents from multiple patent offices, adapt the patent reference numbers to their own specific format.

For instance, a patent application published by the Italian Patent and Trademark Office is given the publication number MO2006A000199 (composed of a region code, the year, a letter code indicating type of protection, and a serial number including three zeros) but is recorded in the esp@cenet search portal with the publication number IT2006MO00199 (adding a country code, while omitting the letter code indicating the type of protection and a zero in the serial number).



One approach for presenting patent reference numbers is given by WIPO Standard ST.10/C at: <http://www.wipo.int/standards/en/pdf/03-10-c.pdf>. However, in the absence of a universally applied standard for number and date formats, it is critical to refer to database documentation in order to obtain satisfactory search results.

Search by applicant/assignee name or by inventor name

Information on the patenting activities of specific individuals, companies or organizations may be obtained quickly by searching patent documents according to their names. The same techniques as described in the section on searching by keywords can be used for this purpose (word operators, truncation, nesting, and phrases).

Careful!

Name variations. It is not uncommon for a single applicant to appear under different names in patent documents. The name may simply be misspelled, abbreviated (e.g., "Limited" or "Ltd.") or may change over time (e.g., "International Harvester" was renamed "Navistar International Corporation" in 1986).

Search in specific data fields

It is often desirable to search for words, numbers, or combinations thereof in a particular data field rather than in the whole document. For instance, a user might want to search for a certain keyword only in the title or abstract of a collection of patent documents.

In some search services, search elements can be entered into different predefined search fields.

PATENTSCOPE® structured search

Home > IP Services > PATENTSCOPE® > Patent Search

PATENTSCOPE®
Search International Patent Applications

This facility allows you to search 1,421,870 international patent applications and to view the latest information and documents available to the International Bureau.

Structured Search options results

> Keywords

AND <input type="checkbox"/>	Publication Number <input type="checkbox"/>	<input type="text"/>
AND <input type="checkbox"/>	Application Number <input type="checkbox"/>	<input type="text"/>
AND <input type="checkbox"/>	Publication Date <input type="checkbox"/>	<input type="text"/>
AND <input type="checkbox"/>	English Title <input type="checkbox"/>	<input type="text"/>
AND <input type="checkbox"/>	English Abstract <input type="checkbox"/>	<input type="text"/>
AND <input type="checkbox"/>	Applicant Name <input type="checkbox"/>	<input type="text"/>
AND <input type="checkbox"/>	Int. Class <input type="checkbox"/>	<input type="text"/>
AND <input type="checkbox"/>	Inventor Name <input type="checkbox"/>	<input type="text"/>
AND <input type="checkbox"/>	National Phase Country <input type="checkbox"/>	<input type="text"/>
AND <input type="checkbox"/>	Description <input type="checkbox"/>	<input type="text"/>
AND <input type="checkbox"/>	Claims <input type="checkbox"/>	<input type="text"/>

Some search services allow users more flexibility in organizing their searches through the use of field codes. Field codes uniquely identify a particular data field in a document and are inserted in front of search elements (keywords, etc.), usually separated by a backslash (\) or colon (:). Field codes vary among search services and must be obtained from the guidance provided by each search service. Search elements not preceded by field codes are searched for in all data fields.

For example, in the advanced search function of the WIPO PATENTSCOPE® search service, the field code “DE” is associated with the “Description” field.

semiconductor	→	documents having the word “semiconductor” in any data field
DE/semiconductor	→	documents having the word “semiconductor” in the “ Description ” data field

The first search would return all patent documents containing the word “semiconductor,” including documents in which the word does not appear in the “Description” field. Thus, any patent application filed by the company Freescale Semiconductor would also be included in the results, even those not actually relating to semiconductor technology, since the word “semiconductor” would turn up in the “Applicant Name” field.

Using citations and reference information

Patent applications often contain references to earlier patent documents (e.g., patent applications or granted patents) or to information published in scientific and technical literature (e.g., journals or handbooks), particularly in the description section of the application. Moreover, in the course of the procedure for obtaining a patent, patent examiners prepare reports in which they may cite patent documents or other documents describing similar or closely related technical solutions to the one for which the patent is being sought. These reports are made available to the public by most patent offices. Citations contained in patent documents can be a useful way of identifying additional documents related to the technology being investigated or help uncover further search criteria.

A common standard used for classifying documents cited by patent examiners in their search report according to their relevance provides for several categories of documents, the most prevalent of which are:

- **Category X.** Document that, taken alone, anticipates the claimed invention, as a result of which the claimed invention cannot be considered novel or cannot be considered to involve an inventive step;

- **Category Y.** Document that, in combination with one or more other such documents, anticipates the claimed invention, insofar as such a combination can be considered obvious to a person skilled in the art;
- **Category A.** Document providing technical background information on the claimed invention.

The example below provides an illustration of how these different categories are used.

For further information on this classification system for cited documents, see: <http://www.wipo.int/standards/en/pdf/03-14-01.pdf>

Sample international search report (ISR)

INTERNATIONAL SEARCH REPORT		International Application No PCT/AT 02/00172
A. CLASSIFICATION OF SUBJECT MATTER IPC 7 ¹ B62M3/08		
According to International Patent Classification (IPC) or to both national classification and IPC		
B. FIELDS SEARCHED Minimum documentation searched (classification system followed by classification symbols) IPC 7 ¹ B62M		
Documentation searched other than minimum documentation to the extent that such documents are included in the fields searched		
Electronic data base consulted during the international search (name of data base and, where practical, search terms used) EPO-Internal, WPI Data, PAJ		
C. DOCUMENTS CONSIDERED TO BE RELEVANT		
Category *	Citation of document, with indication, where appropriate, of the relevant passages	Relevant to claim No.
X	FR 516 494 A (DANEL FRANCOIS-LEOPOLD-AUG) 19 April 1921 (1921-04-19) abstract; figures	1
Y	US 5 628 710 A (HERVIG DANA P) 13 May 1997 (1997-05-13) abstract; figures	4
Y	FR 2 753 953 A (FRECHAUT JEAN) 3 April 1998 (1998-04-03) abstract; figures	4
X	WO 00 68067 A (BADARNEH ZIAD) 16 November 2000 (2000-11-16) abstract; figures	1
A		1,4,5
<input type="checkbox"/> Further documents are listed in the continuation of box C.		<input checked="" type="checkbox"/> Patent family members are listed in annex.
* Special categories of cited documents:		
'A' document defining the general state of the art which is not considered to be of particular relevance 'E' earlier document but published on or after the international filing date 'L' document which may throw doubts on priority claims or which is cited to establish the publication date of another claim or other special reason (as specified) 'O' document relating to an oral disclosure, use, exhibition or other means 'P' document published prior to the international filing date but later than the priority date claimed		'I' later document published after the international filing date or priority date and not in conflict with the application but cited to understand the principle or theory underlying the invention 'X' document of particular relevance; the claimed invention cannot be considered novel or cannot be considered to involve an inventive step when the document is taken alone 'Y' document of particular relevance; the claimed invention cannot be considered to involve an inventive step when the document is combined with one or more other such documents, such combination being obvious to a person skilled in the art. 'A' document member of the same patent family
Date of the actual completion of the international search 10 September 2002		Date of mailing of the international search report 17/09/2002
Name and mailing address of the ISA European Patent Office, P.B. 5818 Patentamt 2 St. - 2280 Nußdorf Tel. (+31-70) 340-2040, Tx. 31 851 apo nL Fac. (+31-70) 340-3076		Authorized officer Wagner, H
Form PCT/ISA/210 (second sheet) July 1992		

Good practices in searching patent documentation

The most effective searches exploit all the search options elaborated above, by using and combining keywords, IPC symbols, and number/date ranges, as supported by the search service used.

Effective searching of patent documentation is a step-by-step process, moving from an initial broad search to increasingly more focused searches. Casting a wide net at first will allow you to uncover unexpected – but nonetheless potentially relevant – search results, as well as identify additional search criteria for subsequent searches. Ultimately, however, the number of search results must be limited to a reasonable number to allow the individual records to be examined in detail.

To this end, the following issues should be considered when developing a search strategy:

- **Broad vs. specific search terms.** The keywords and IPC symbols used in the first rounds of searching should cover the broad field of technology to which the innovation in question belongs. For example: if you are searching for information on light-emitting diodes, you may want to initially search using keywords such as “semiconductor” or IPC symbols such as the subclass “H01L” (semiconductor devices) rather than the group “H01L 33/00” (semiconductor devices specially adapted for light emission).
- **Inclusive/exclusive search operators.** Certain search operators can be used to broaden your search (inclusive operators), while others serve to narrow your search (exclusive operators).

Inclusive operators are, for example, “OR” and any wildcard operator (since all word combinations based on the word stem to which a wildcard operator is applied are included in the results).

Exclusive operators are, for instance, “AND”, since results must contain both words or phrases joined by this operator, and quotation marks, since results must contain the exact phrase inside the quotation marks.

As shown in the diagram below, narrowing the search scope should increase the proportion of relevant records included in the search results, i.e., increasing the precision of the search. However, narrowing the search scope may also decrease the number of relevant records retrieved, i.e., decreasing the recall of the search.

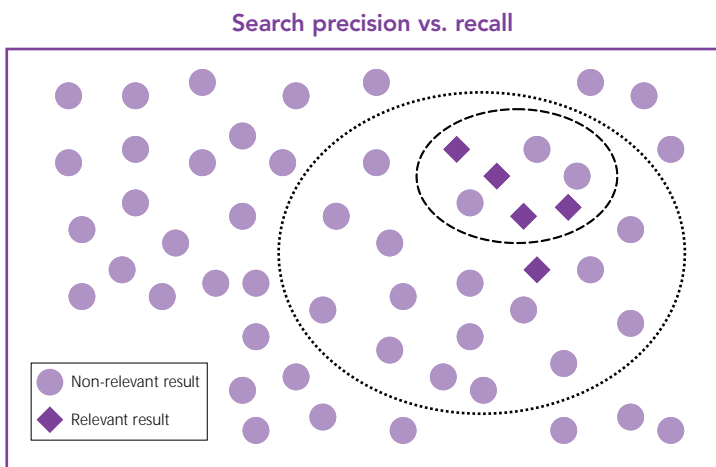

Precision. In the diagram above, the wider search (represented by the dotted line) produces 23 results of which only five, or approximately 20 percent, are relevant, while the narrower search (represented by the dashed line) produces seven results of which four, or more than half, are relevant.

Recall. Above, the wider search retrieves all five, or 100 percent of, relevant results, while the narrower search retrieves only four of five, or 80 percent of, relevant results.

▶▶ How can patent information be used?

Patent documents include a broad range of technical and legal information that can be used for a number of different purposes including:

- Prior art searches;
- Gathering business intelligence;
- Avoiding patent infringement;
- Patent valuation;
- Identifying key trends in technology development.

In the examples given in the section below, the WIPO PATENTSCOPE® search service is used for illustrative purposes, but similar approaches can be taken using other patent and non-patent search services.

The steps described in the practical cases may be used as guidance in performing your own searches.

Prior art searches

Among the criteria that are used to determine the patentability of a claimed invention are:

- Novelty: Is an invention new?
- Non-obviousness/Existence of an inventive step: Is the invention sufficiently different from existing technologies?

To determine whether a claimed invention meets these criteria, it must be compared to the prior art, i.e., the pool of existing knowledge made available to the public anywhere around the world. Patent documents are an important channel through which technical information is made publicly available. Consequently, searching patent documents is an important step in determining whether an invention is ultimately patentable.

Before conducting a patentability search for existing patent documentation, it is important to determine the characteristics of the innovation for which you are considering seeking patent protection:⁴

- What problem does your invention solve?
- What does your invention do?
- What effect does your invention produce?
- How is your invention constructed?
- What materials or methods are used in the construction of your invention?

Answers to these questions should then be distilled into essential words and phrases that will be used in searching existing patent documentation.

Remember that existing patents in fields of technology not obviously related to the innovation at hand may contain information that has a bearing on the patentability of your invention. For example, your invention relates to a novel blade design for a wind turbine. Patents on the design of helicopter rotor blades, airplane wings, or other aerodynamic structures may contain relevant prior art. As a result, the scope of your search should not be restricted unnecessarily to avoid missing relevant documents.

Careful!

Non-patent literature. An important contribution to prior art in many technical fields is made by non-patent literature, including scientific and trade journals. An exhaustive search for prior art must therefore take into account this body of information.

Alternative types of IP protection. Some countries offer types of IP protection apart from patents including utility models, petty patents, or similar. The information disclosed in applications for these types of protection also represents prior art that must be considered in determining the patentability of an invention.

Patent laws. Legal requirements for patentability, such as the extent of the inventive step needed to obtain a patent for a particular invention, may vary from one jurisdiction to another. Therefore, it may be useful to seek the advice of a patent professional if a preliminary patentability search does not reveal any prior art that clearly invalidates your potential patent claims.

⁴ Considering these questions may also assist you in improving the quality of an eventual patent application.



Practical case

You have developed a method for printing solar cells onto aluminum foil at low temperatures using a nanoparticle “ink”.

Step 1. Identify central concepts related to your innovation

From the description offered above, central concepts could include: “solar cell” (product), “aluminum foil”, “nanoparticle ink” (materials used in the production process).

Step 2. Determine keywords for your search

The next step is to find synonyms and related keywords and phrases for the concepts identified in the first step:

solar cell	→	photovoltaic cell (synonym)
aluminum foil	→	aluminium foil (alternative spelling), metal foil (related term)
nanoparticle ink	→	nanoparticle solution (related term), nanoparticle suspension (related term)

Step 3. Determine IPC symbols for your search

Using some of the words and phrases found in the previous steps, the pertinent IPC symbols can be located through a keyword search in the IPC (see: <http://www.wipo.int/tacsy>). Searching for the term “solar cell” using the default settings identifies the IPC group H01L 31 as a relevant IPC symbol.

Keyword search in the IPC

The screenshot shows the WIPO TACSy search interface. The search query is "solar cell". The search results are displayed in a table format. The first result is H01L 31/00, which is highlighted. The search results are as follows:

IPC Class	Description
H01L 31/00	Semiconductor devices sensitive to infra-red radiation, light, electromagnetic radiation of shorter wavelength, or corpuscular radiation and specially adapted either for the conversion of the energy of such radiation into electrical energy or for the control of electrical energy by such radiation; Processes or apparatus specially adapted for the manufacture or treatment thereof or of parts thereof; Details thereof (H01L 51/42 takes precedence; devices consisting of a plurality of solid state components formed in, or on, a common substrate, other than combinations of radiation-sensitive components with one or more electric light sources; H01L 27/00; roof covering aspects of energy collecting devices; H04D 13/16; production of heat using solar heat [28.7.340]; measurement of β -radiation, gamma radiation, corpuscular radiation or cosmic radiation with semiconductor detectors G01T 1/24; with resistivity detectors G01T 1/30; measurement of neutron radiation with semiconductor detectors G01T 3/06; couplings of light guides with optoelectronic elements G02B 6/42; obtaining energy from radioactive sources G21H) [2.A.6]
H01L 31/02	- Details [2]

The search results also show a list of IPC codes proposed for the search, including G05F 5/67, H01L 31/542, H01L 31/50, G01J 5/28, and H01J 29/45. The H01L 31/00 code is circled in red in the original image.

Step 4. Perform first search

The first searches should be relatively broad, using (i) the “OR” Boolean operator to join related keywords and IPC symbols; and (ii) a wildcard operator to include plural forms of words and phrases. Since IPC symbols should only be located in the international class field of the patent documents searched, the “International Class” operator (“IC/”) can be used in the WIPO PATENTSCOPE® search service (advanced search function) to restrict the search for IPC symbols to this field.

The first search will focus on finding a broad range of patent applications relating to the product in question:

“solar cell*” OR “photovoltaic cell*” OR IC/H01L-31*

PATENTSCOPE® advanced search

Home > IP Services > PATENTSCOPE® > Patent Search

PATENTSCOPE®
Search International Patent Applications

This facility allows you to search 1,421,870 international patent applications and to view the latest [information and documents](#) available to the International Bureau.

Advanced Search options results

> Date All Week of:

> Search: Front Page Full Text

Example: et/needle or et/syringe andnot (sew* or thread) or WO/2005/012345 or PCT/U52004/012345

This search produces over 7000 results, a number of results far too great to allow a detailed review of individual records. Examining the results reveals that they include applications covering not only methods for producing solar cells but also for arranging and using solar cells. The results also cover a much broader range of basic construction materials than apply to the innovation whose patentability you are seeking to examine.

PATENTSCOPE® search results

Results of searching in PCT for:
 "solar cell" OR "photovoltaic cell" OR IC:H01L-31* 7142 records
 Showing records 1 to 25 of 7142

Next 25 records Search Start At:

Refine Search: "solar cell" OR "photovoltaic cell" OR IC:H01L-31* RSS

Title	Pub. Date	Int. Class	App. Num.	Applicant
1. WO/2008/04270 WIRELESS NETWORK CAMERA SYSTEM	29.05.2008	H04N 7/18	PCT/US2007/065308	SECROPPOWER APPLIANCE
Apparatus, systems and techniques associated with battery powered wireless camera systems. One aspect of the subject matter described in this specification can be embodied in a system that includes a battery powered wireless camera including an internal battery to provide energy and a burst transmission unit to transmit information during burst periods. The system includes a base station, separated from the battery powered wireless camera, in wireless communication with the battery powered wireless camera to receive information from the battery powered wireless camera. The base station is configured to process the received information and includes a web server to transmit the processed information to a client. Other embodiments of this aspect...				
2. WO/2008/04189 WIRELESS NETWORK WITH NODES HAVING MULTIPLE ANTENNAS	29.05.2008	H04L 12/06	PCT/US2007/065150	QUALCOMM COMMUNICATIONS, INC.
An architecture and protocol stack for multi mesh wireless networks, where one or more nodes and/or clients in the network have more than one antenna. One or more frequency bands and support devices with different communication protocols can be utilized.				

Step 5. Sharpen search

Taking into account the results from our preliminary search, the search should be limited using more specific search terms and linked using the "AND" Boolean operator. Nesting should be used to resolve any potentially ambiguous search syntax. In order to capture results containing wordings such as "nanoparticle solution" as well as "solution containing nanoparticles," we will use the "NEAR" Boolean operator, as follows:

```
(IC:H01L-31* OR "solar cell*" OR "photovoltaic cell*")
AND ("aluminum foil*" OR "aluminium foil*" OR "metal foil*")
AND ((nanoparticle* NEAR ink*) OR (nanoparticle* NEAR solution*)
OR (nanoparticle* NEAR suspension*))
```

PATENTSCOPE® advanced search

Home > IP Services > PATENTSCOPE® > Patent Search

PATENTSCOPE®
 Search International Patent Applications

This facility allows you to search 1,421,870 international patent applications and to view the latest [information and documents](#) available to the International Bureau.

Advanced Search options results

> Date All Week of:

> Search: Front Page Full Text

Example: ethneedle or eSyringe andnot (sew* or thread) or WO/2005/012345 or PCT/US2004/012345

This search produces 25 results, a more manageable number of results. Among the results are several international applications by Nanosolar Inc. as well as Hewlett-Packard Development Company L.P. describing, for instance, "Mettalic [sic] Dispersion and Formation of Compound Film for Photovoltaic Device Active Layer" and a "Method of Forming a Solution Processed Transistor Having a Multilayer Dielectric," both of which have potential relevance to the patentability of your new innovation.

PATENTSCOPE® search results

Home > IP Services > PATENTSCOPE > Patent Search

Results of searching in PCT for:
 (ICN01L-31" OR "solar cell" OR "photovoltaic cell") AND ("aluminum foil" OR "aluminium foil" OR "metal foil") AND ((nanoparticle" NEAR ink") OR (nanoparticle" NEAR solution") OR (nanoparticle" NEAR suspension")); 25 records
 Showing records 1 to 25 of 25

[\[Search Summary\]](#)

Refine Search: ICN01L-31" OR "solar cell" OR "photovoltaic cell"

Title	Pub. Date	Int. Class	App. Num	Applicant
1. (WO 2008057045) NANOPARTICULATE ETHANOLATION BARRIER STACK	15.05.2008	C09K 11/00	PCT/SG2006/000334	AGENCY FOR SCIENCE, TECHNOLOGY AND RESEARCH
A barrier stack for encapsulating a moisture and/or oxygen sensitive electronic device is provided. The barrier stack comprises a multilayer film having at least one barrier layer having low moisture and/or oxygen permeability, and at least one sealing layer arranged to be in contact with a surface of the barrier layer, wherein the sealing material comprises reactive nanoparticles capable of interacting with moisture and/or oxygen, thereby retarding the permeation of moisture and/or oxygen through defects present in the barrier layer.				
2. (WO 2008045311) ILLUMINATION DEVICE WITH BUILT-IN LIGHT COUPLER	17.04.2008	G02B 6/00	PCT/US2007/021376	QUJALCOMM MEMS TECHNOLOGIES, INC.
The invention comprises devices and methods for coupling a light source to a display illumination device. In one embodiment, an illumination device includes a light guide comprising a front surface, a back surface, a light coupling section configured to receive optical energy from a light source in to the light guide through said front surface or said back surface at an angle about normal to the optical energy receiving surface, and further configured to direct light through said light guide, and a light turning section configured to redirect out of the light guide at least a portion of the light received from said light coupling section, said redirected light at an angle about normal to the optical energy receiving surface.				

A similar search performed in the patent application database of the US Patent and Trademark Office reveals an application assigned to Nanosolar Inc. entitled "Formation of compound film for photovoltaic device." In fact, this patent document is cited as a priority document in the international application "Mettalic [sic] Dispersion and Formation of Compound Film for Photovoltaic Device Active Layer" filed by Nanosolar Inc., uncovered by the PATENTSCOPE® search above.

Gathering business intelligence

Knowing which companies or individuals are technology leaders in your area of business can play an important role in planning your commercial and research and development activities. Patenting activity and patent ownership can be important in identifying principal innovators in different areas of technology.

Though a search will reveal any patent documents meeting the specified search criteria that are published at the time the search is performed, new applications emerge over time that are relevant to your business. To keep track of these developments, some search services offer the possibility of requesting email updates or establishing customized RSS feeds, which are continuously updated to reflect newly published documents and can be accessed using common software applications.

Careful!

Trade secrets. Rather than seeking patent protection for an innovation and accepting the mandatory disclosure associated with applying for a patent, some businesses may seek to protect their ideas by keeping them confidential, particularly if these innovations are susceptible to reverse engineering. Thus some of your competitors' innovative activities and strategies for the future may not be revealed through a patent search.

Commercialization. A technology need not be commercialized by the patent holder but may also be licensed to one or more third parties. As a result, published patent applications may not always fully reflect the business activities of competitors.



Practical case

Your company produces farm equipment and would like to keep track of new developments in plow technology on the international market.

Step 1. Determine criteria for your search

An obvious choice would be to search for patent applications using the keyword “plow.” However, keyword searches can be easily misled by alternative spellings (e.g., “plough”), technical terminology, obfuscation, or foreign language applications. Therefore, it may be advisable to use IPC symbols to find relevant applications.

Searching the IPC according to keywords (see: <http://www.wipo.int/tacsy>) reveals that several IPC groups are related to plow technology.

Keyword search in the IPC

The screenshot shows the WIPO TACSYS search interface. The search query is "plow". The results are displayed in a table with the following columns: IPC code, description, and a small icon. The results are as follows:

IPC code	Description
A01B 1/00	Ploughs, harrows or similar machines
A01B 1/02	Plough blades. Filing the blades
A01B 1/04	Shares
A01B 1/06	Interchangeable or adjustable shares
A01B 1/08	Mouldboards
A01B 1/10	Interchangeable or adjustable mouldboards
A01B 1/12	Beams. Handles (handles for tools or their attachment in general E25G)
A01B 1/14	Frames (means or arrangements to facilitate transportation A01B 7/00) [4]
A01B 1/16	Discs (bearings therefor A01B 7/04). Scrapers for cleaning discs. Sharpening attachments (sharpening in general E24)
A01B 1/18	Coulters
A01B 1/20	Special adjusting means for loos of ploughs (down to), or mounted on tractors working on hillsides or slopes
A01B 1/00	Ploughs with special additional arrangements, e.g. means for pulling moisture under the soil, chod-crushers (A01B 48/00 takes precedence; ploughs for working without A01B 1/00) [2]

The search interface also shows the search language set to English, the IPC language set to Default, and the answer depth set to Automatic. The level is set to Advanced. The search results are displayed in a table with a 'Select here' dropdown and a 'Submit' button. The 'IPC codes proposed' section is highlighted with a red circle, and the search input field is also highlighted with a red circle.

Step 2. Perform search

Since multiple IPC groups seem to be relevant, you should include all of these groups identified in the first step in your search. This can be done using the "OR" Boolean operator. To include all subgroups in your search, it is necessary to append a wildcard operator to each IPC symbol. Since you are interested only in searching the international classes of patent documents, you can limit your search to the appropriate field in the WIPO PATENTSCOPE® search service (advanced search function) by using the "International Class" field code ("IC") in front of the relevant IPC symbols as follows:

```
IC/"A01B 3/*" OR IC/"A01B 5/*" OR IC/"A01B 7/*" OR IC/"A01B 9/*"
OR IC/"A01B 11/*" OR IC/"A01B 13/*" OR IC/"A01B 15/*" OR
IC/"A01B 17/*"
```

PATENTSCOPE® advanced search

Home > IP Services > PATENTSCOPE® > Patent Search



Search International Patent Applications

This facility allows you to search 1,421,870 international patent applications and to view the latest [information and documents](#) available to the International Bureau.

Advanced Search options ▾ results ▾

» **Date** All Week of:

» **Search:** Front Page Full Text

```
IC/"A01B 3/*" OR IC/"A01B 5/*" OR IC/"A01B 7/*" OR
IC/"A01B 9/*" OR IC/"A01B 11/*" OR IC/"A01B 13/*" OR
IC/"A01B 15/*" OR IC/"A01B 17/*"
```

Example: et/needle or et/syringe andnot (sew* or thread) or WO/2005/012345 or PCT/US2004/012345

This search retrieves around 160 results, including applications covering "ground or soil-working tools and machines" and an "agricultural cutting tool that engages the soil."

Step 3. Analyze the data

From the WIPO PATENTSCOPE® search service results page, you can quickly navigate to in-depth analysis of the results and visualize the patenting activity in your area of interest in graphical format, as shown below.

PATENTSCOPE® search results



This tool provides a range of useful information regarding the countries of origin of international applications relevant to your search criteria as well as historical filing patterns, subclasses to which relevant applications belong, and top applicants in the field in which you have searched. Thus, for example, the graphical tool identifies the Norwegian firm Kverneland Klepp A.S. as a top PCT applicant in the field of plow technology.

Visualization of search results by applicant



Step 4. Keep track of current information

From the WIPO PATENTSCOPE® search service results page you can also access RSS feeds as shown below. By subscribing to the RSS feed, you can remain up-to-date on the latest international applications relevant to your business interests, since the content of the feed is continuously updated as new applications are published that meet the criteria specified for the original search.

PATENTSCOPE® search results

Results of searching in PCT for:
 IC^oA01B 3^o OR IC^oA01B 5^o OR IC^oA01B 7^o OR IC^oA01B 9^o OR
 IC^oA01B 11^o OR IC^oA01B 13^o OR IC^oA01B 15^o OR IC^oA01B
 17^o 161 records
 Showing records 1 to 25 of 161

Next 25 records

Search Settings

Start All

Retine Search: IC^oA01B 3^o OR IC^oA01B 5^o OR IC^oA01B 7^o OF

Title	Pub. Date	Int. Class	App. Num	Applicant
1. (WO/2006/022376) COMBINED ROTARY SCRAPING TOOL AND PRESS WHEEL FOR A COULTER	26.02.2006	A01B 15/16	PCT/AU2007/601167	FOSTER, Dale
2. (WO/2006/022377) AGRICULTURAL IMPLEMENT WITH GAUGE WHEEL	26.02.2006	A01B 63/16	PCT/AU2007/601167	FOSTER, Dale, Anthony

The present invention relates generally to a coultter scraping assembly (10) incorporating a coultter scraping tool (12) which includes a rotary blade (18). The rotary blade (18) is dish-shaped being shallow with a relatively narrow profile and including a narrow working edge (24). The working edge (24) is configured to cooperate with the coultter (18) for scraping excess material, such as soil particles and trash which has built up on the coultter (18).

An agricultural implement (10) is disclosed. It has a support (12) adapted to be attached to an agricultural vehicle. It also has a soil engaging tool (18) attached to the support (12). The implement 10 includes a gauge wheel (16) movably coupled to the support (12) for forward or rearward movement relative to the soil engaging tool (16).

Avoiding patent infringement

Costly legal procedures associated with patent infringement can often be avoided by gathering information on the scope of existing patents and their legal status in the jurisdictions in which you plan to establish business operations. This information can be obtained by way of systematic searching of patent documents. Such a search should include patent documentation for the PCT system and for national and regional jurisdictions in which you wish to commercialize the technology in question. Having identified relevant patent documents, the first step is to examine the legal status of the patent application:

- Has the patent been granted, rejected, withdrawn, or is it still pending?
- In which countries?
- Is the patent still valid, or has it expired?

If a patent is in force in a particular jurisdiction in which you wish to market your product, the second step is to appraise the claims made under this patent. Potential infringements can be avoided by modifying your product to take into account these claims. Since patent applications are not published until around 18 months after they are filed, it is important to continue monitoring patent documentation in fields of technology related to your product. Many search services incorporate notification tools, e.g., RSS feeds, that can greatly facilitate this process.

Patent valuation

Patent documentation can provide an indication as to the value of patents that you or your competitors have been granted. In particular, the citation information contained in patent documents – notably other patents, patent applications, or national or International Search Reports (ISRs) – subsequent to a particular patent can be useful for estimating the value of the patent in question. For example, the number of times a patent is cited in later patent documents is indicative of its technical relevance and thus of its value.

A number of search services are offered by patent offices and commercial providers that allow the analysis of citation information, in particular by identifying later patent documents that cite a particular patent. One such service is provided by the European Patent Office at:

<http://www.epoline.org/portal/public/registerplus>

Careful!

Patent value. The commercial value of a patent depends on many factors that may not be reflected in patent documentation, including the ability of the patent holder or licensee to promote products based on the protected technology as well as the size of the potential market.

Identifying key trends in technology development

Statistical data obtained from patent documents can be used to map key trends across different fields of technology and different countries, thereby helping policymakers make better informed decisions.

Patent data can be obtained through national and regional patent offices' statistical publications, notably their annual reports, which are often released through the patent offices' websites. WIPO provides access to a broad range of statistics on world patent activity at: <http://www.wipo.int/ipstats/en/statistics/patents>

The data generally describes the number of patents filed, granted, and in force in different countries and may be broken down according to a number of criteria including by technology group or by country of origin of applicant or inventor.

Depending on the criteria according to which patent data can be broken down, it can, for instance, be used to track the growth and changes in patent activity over time, examine the distribution of patent applications in a country by residents compared to non-residents, or identify the technical areas in which a country is predominantly active in terms of patenting activity.

One patent statistic used by certain government agencies in planning their industrial development strategy is the "relative specialization index," as shown below. This index compares the country's share in global patent activity in one technology area to the country's share in global patent activity over all areas of technology. It may be useful to identify the relative strengths and weaknesses of a country in terms of patenting activity and thus highlight possible areas to be targeted for investment.

Relative specialization index showing concentration
of patenting activity in a specific country

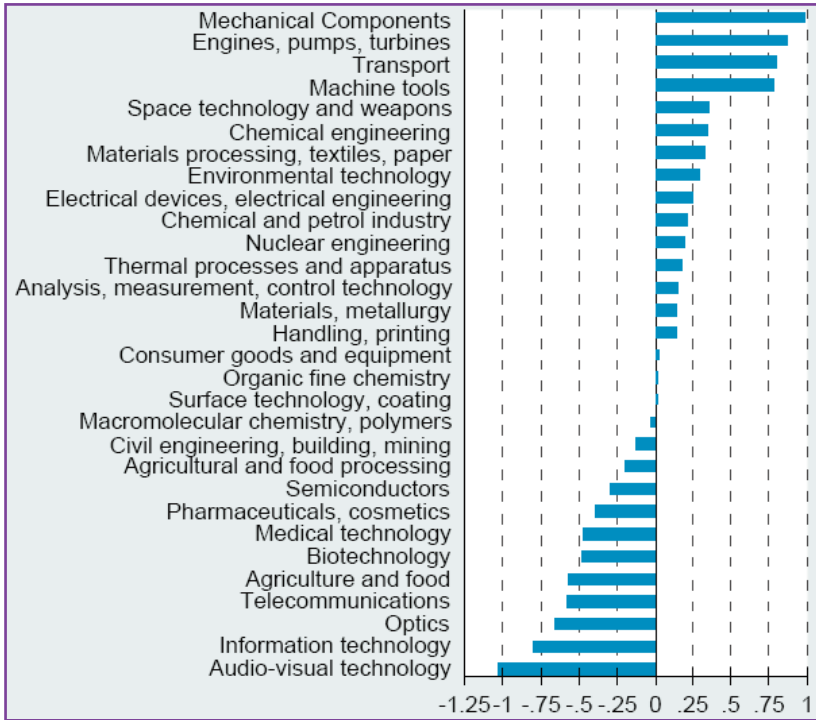

Source: PCT Quarterly Report: Trends and Analysis, WIPO



Practical case

Your government has identified the absence of adequate food preservation technology as a key obstacle to the further development of the agricultural export sector and is considering negotiating technology transfer agreements with other countries in order to obtain better access to relevant technologies.

Step 1. Determine criteria for your search

Browsing the IPC shows that, in this specific case, an IPC group exists that appears to cover the field of technology in question, namely A23L 3.

Finding the appropriate IPC symbol

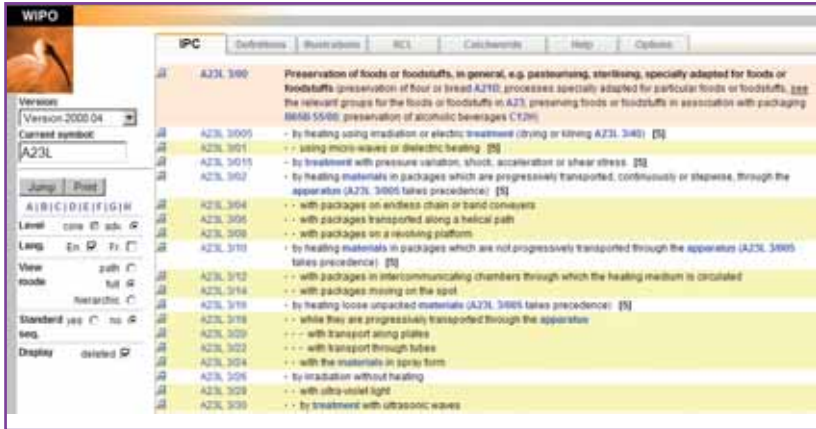

Step 2. Perform search

Since only a single IPC group is required to cover the field of technology at hand, the search criteria required to identify relevant records is exceptionally simple in this case. The IPC symbol identified in the first step can be entered into the appropriate field in the WIPO PATENTSCOPE® search service (advanced search function).

PATENTSCOPE® advanced search

Step 3. Analyze the data

Summary data and graphical representations of the international patent applications identified in the previous step can be quickly obtained from the results page, as shown below.

PATENTSCOPE® search results

Results of searching in PCT for:
ICIA23L-3P, 1979 records
Showing records 1 to 25 of 1979

Next 25 records

Search Summary

Start at

Refine Search ICIA23L-3P

Title	Pub. Date	Int. Class.	App. Num.	Applicant
1. WO/2008/053050 ASSEMBLY AND METHOD FOR DRYING A PRODUCT	28.05.2008	A23L 3/40	PCT/NL2007/000078	WAGENINGEN UNIVERSITY
The application relates to an assembly for drying a product, comprising at least one drying device and at least one adsorption device, in which the adsorption device is provided with regenerable adsorption material for extracting water from a gas and comprises a gas inlet and a gas outlet, and is adapted to bring the gas into contact with the regenerable adsorption material between the gas inlet and the gas outlet, the drying device is adapted to transport the product along a drying section and comprises a first gas inlet, a second gas inlet situated at a distance from the first gas inlet, a first gas outlet, and a second gas outlet situated at a distance from the first gas outlet, in which the gas inlets and gas outlets of the drying dev...				
2. WO/2008/02181 ADJUSTABLE STEAM INJECTOR	22.05.2008	B01F 5/04	PCT/SE2007/000995	TETRA LAIL HOLDINGS & FINANCE SA
The present invention relates to an adjustable steam injector (1) of the type which has an injector housing (2) with an inlet (3) for product which is to be heated and an outlet (4) for the heated product. The injector housing (2) also has an inlet (5) for steam. The injector (1) also includes an injector body (6) displaceable in the injector housing (2) and having, in its one end, a centre pin (8). Around the centre pin (8) there are disposed concentric gaps (9, 10) for product and steam, respectively. The centre pin (8) is formed so that it has a number of grooves (12) accommodated on its circumferential surface. The grooves (12) are turned towards the one end of the centre pin (8).				

The information obtained using the graphical analysis tool includes the number and distribution of international applications relating to the search criteria used in the second step, that is to say, in the field of food preservation technology.

Visualization of search results by country of origin

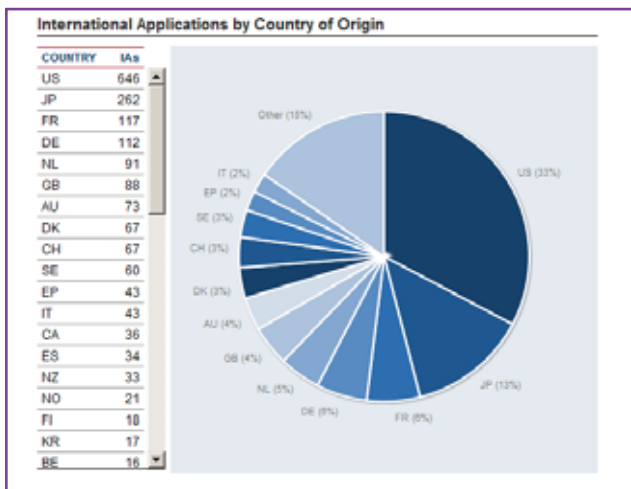

It also includes information on historical trends in the filing of international applications in this field. The number of applications for the current year only reflects the number of applications published at the time of the search and thus may appear surprisingly low.

Visualization of search results by publication year

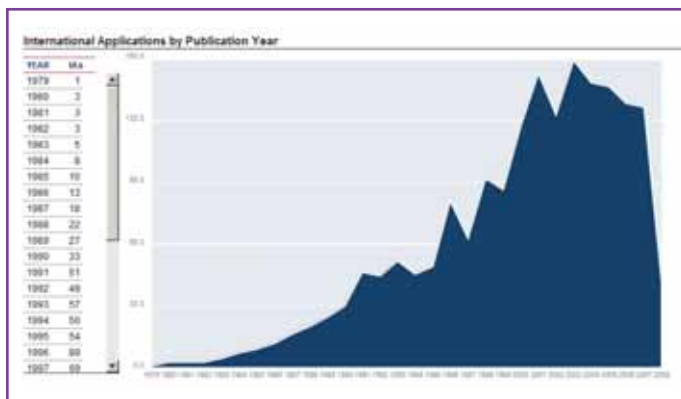

►► Where can non-patent literature be located?

Non-patent literature includes scholarly journals, textbooks and other sources of scientific and technical knowledge. In many fields of technology, non-patent literature plays a central role in defining the prior art and is, therefore, indispensable for determining the patentability of any innovation.

WIPO has established a list of periodicals that intellectual property offices must consult when carrying out international searches as part of the patenting process under the PCT system. This list, known commonly as the PCT Minimum Documentation, is available at: http://www.wipo.int/standards/en/part_04.html

A thorough consultation of the periodicals included in the list of non-patent Minimum Documentation is a necessary step for determining whether prior art exists with respect to an innovation. However, additional sources must also be reviewed to determine the novelty of the innovation.

A number of free online tools for searching non-patent literature are offered by commercial providers including Google Scholar and Scirus. Certain commercial providers also provide enhanced search services, including cross-references and IPC-classified non-patent documents, on a fee-paying basis.

We welcome your comments

Suggestions and questions may be sent to patentscope@wipo.int

World Intellectual Property Organization

Address:

34, chemin des Colombettes
P.O. Box 18
CH-1211 Geneva 20
Switzerland

Telephone:

+41 22 338 91 11

Fax:

+41 22 733 54 28

e-mail:

wipo.mail@wipo.int

Visit the WIPO website at:

<http://www.wipo.int>

and order from the WIPO Electronic Bookshop at:

<http://www.wipo.int/ebookshop>